

UK



© Micro-system KH 2267 / 2268
Operating instructions



KH 2267 / 2268

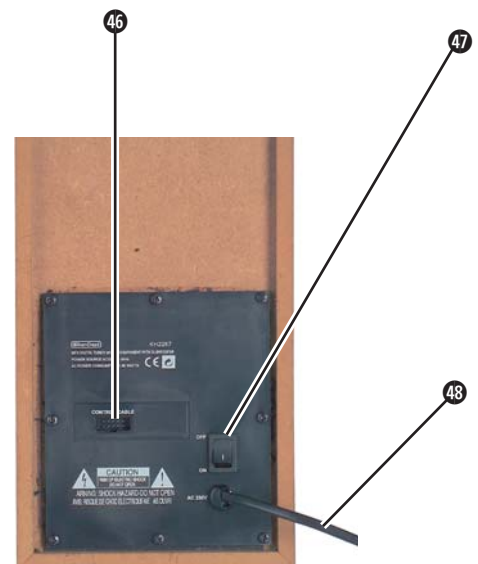
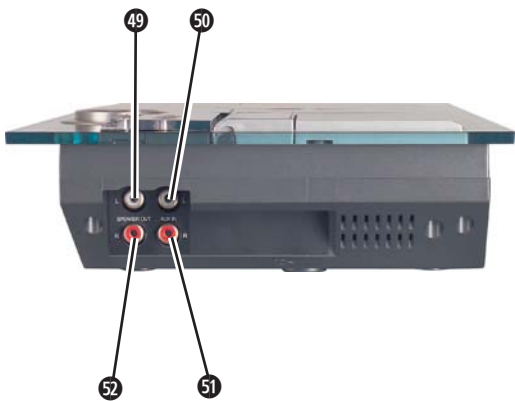
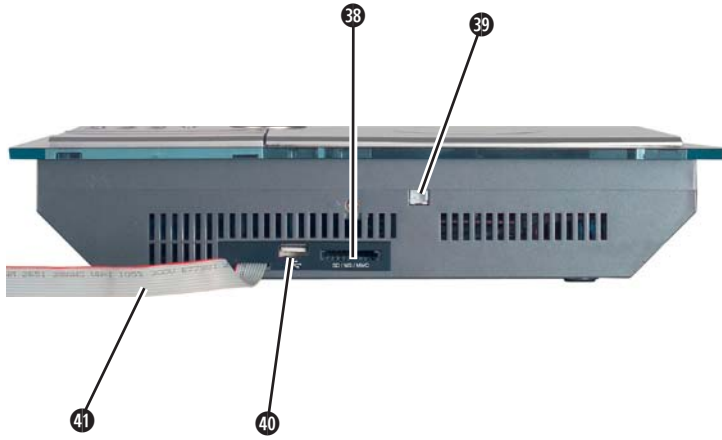
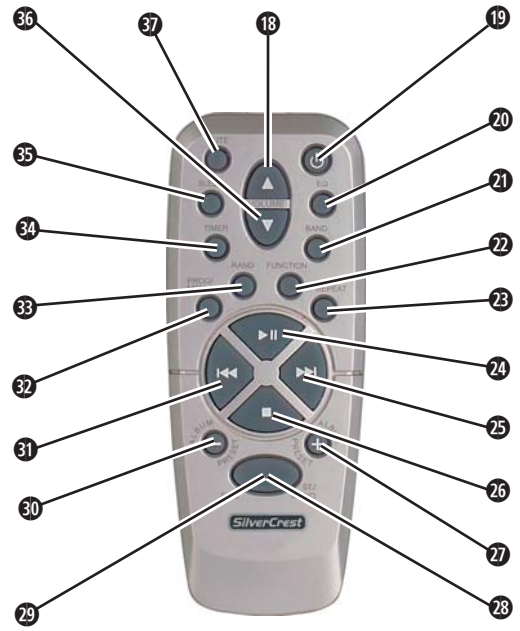
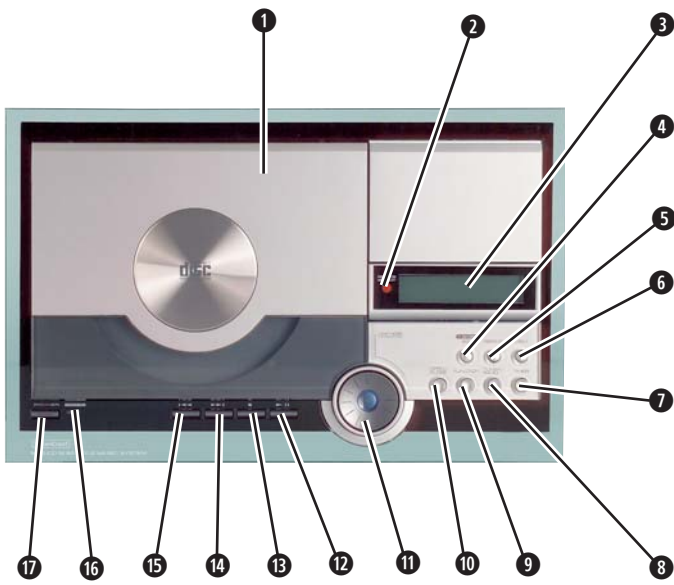

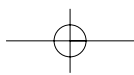
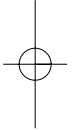
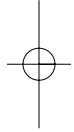

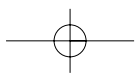
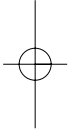
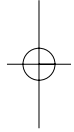

Micro-system SilverCrest KH 2267 / 2268	Page
1. Proper use	4
2. Package contents	4
3. Technical Data	4
4. Safety Instructions	4
5. Wall mounting	5
6. Setting up	5
7. Operating elements	5
8. Inserting batteries into the remote control	5
9. Handling batteries	5
10. Connecting	6
11. Fold out the display for horizontal operation.	6
12. Switching on and off	6
13. Selecting the appliance/sound source.	6
14. Adjusting the volume	6
15. Adjusting the sound	7
16. Using headphones	7
17. Setting the clock	7
18. Setting the alarm function (timer)	7
19. Activating the sleep function (Sleep)	8
20. Radio operation / Selecting a band (USW/MW)	8
21. Operating the radio	8
22. CD functions	8
23. MP3 functions	9
24. USB and memory card functions	11
25. Cleaning and care	11
26. Disposal	11
27. Importer	11
Warranty Card	13

Read the operating instructions carefully before using the appliance for the first time and preserve this booklet for later reference. Hand over the manual to anyone, whom you pass on the appliance to.

KH 2267 / 2268

Micro-system SilverCrest KH 2267/2268

1. Proper use

The micro-system is solely intended for playing music CDs, MP3-CDs, MP3s from MS, SD and MMC cards and for listening to radio programs.

The micro-system is not intended for use in commercial or industrial environments.

No guarantee will be granted for damage resulting from improper use!

2. Package contents

- 1 Micro-system
- 1 Subwoofer
- 2 Loudspeakers
- 2 Loudspeaker legs
- 1 Remote control
- 1 Medium wave antenna
- 1 Operating manual

3. Technical Data

Micro-system

Max. Rated output:	5 watts RMS at 8 ohm per channel
Frequency range radio:	MW (AM): 530 – 1600 KHz
	UKW (FM) : 87.5 - 108 MHz

CD drive

Frequency range (6 dB):	60 - 15000 Hz
Signal-to-noise distance:	40 dB
Flutter:	1%
Channel separation:	35 dB

Subwoofer

Mains voltage:	230 V~, 50 Hz
Power consumption:	85 Watt
Rated output:	15 watts RMS at 4 ohm

4. Safety Instructions

- Do not allow children to handle electrical appliances when unsupervised - because they often underestimate the danger.
- In order to avoid unintentional switching on, disconnect the power cord after each use and before cleaning.
- Check the appliance and all the parts for visible damages. The safety concept can work only if the appliance is in an immaculate condition.

⚠ Explosion Hazard!

- Do not throw batteries into a fire. Do not recharge the batteries.

⚠ Danger of electric shock!

- Connect the appliance to a wall socket with a mains voltage of 230 V ~ /50 Hz.
- Do not use the appliance with a damaged connecting cable or power plug.
- Get customer service to repair or replace connecting cables and/or appliances that are not functioning properly or have been damaged.
- Never immerse the appliance in water. Only wipe it with a slightly damp cloth.
- Do not expose the appliance to the rain and never use it in a humid or wet environment.
- Make sure that the power cord does not become wet during operation.
- Do not open or repair the appliance casing yourself. In such an event, safety is not guaranteed and the warranty shall become void.

⚠ Fire hazard!

- Do not use the appliance near hot surfaces.
- Do not keep the appliance in places that are exposed to direct sunlight, otherwise it may overheat and become damaged.
- Do not leave the appliance unattended when in use.
- Never cover the ventilation slots of the appliance while it is on.

⚠ Danger of injuries

- Keep children away from the connecting cable and the appliance. Children frequently underestimate the danger from electrical appliances.
- Make sure to find a safe place for the appliance.
- Do not operate the appliance if it has sustained a fall or is damaged. Get the appliance checked and repaired by experts, if necessary.
- Keep batteries away from children. Children can put batteries into their mouths and swallow them.

⚠ Danger of injury to the eyes!

- Never look directly into the open CD compartment. The invisible laser beam could damage your eyes.

5. Wall mounting

You can mount the micro-system and the loudspeakers to a wall.

Only mount the appliance and the loudspeakers to a solid wall.

- ⇒ Drill the screwholes for the micro-system into the wall with a horizontal spacing of 19 cm.
- ⇒ Drill the screwholes for the loudspeakers above one another into the wall with a vertical spacing of 13.5 cm.

① So that the screws can grip properly into the mounts on the back of the micro-system, the screw heads must jut out of the wall approx. 3 mm.

- ⇒ Screw two screws into the wall.
- ⇒ Hang the micro-system onto the screws by the two mounts.

6. Setting up

- ⇒ Take the micro-system and the accessories out of the packaging.
- ⇒ Remove all transport securing means and adhesive tape/films.
- ⇒ Set up the micro-system so that the flap of the CD compartment **①** can fully open.
- ⇒ Place one loudspeaker **④②** each on a loudspeaker leg **④③**.
- ⇒ Place the subwoofer and the loudspeakers on an even horizontal surface.
- ⇒ Position one loudspeaker on the right-hand side of the micro-system.
- ⇒ Position one loudspeaker on the left-hand side of the micro-system.

7. Operating elements

- ①** CD compartment
- ②** Sensor for the remote control
- ③** Display
- ④** Sound selection button (X-BASS/EQ)
- ⑤** Repeat button (REPEAT)
- ⑥** Programming button (MEM)
- ⑦** Timer button (TIMER)
- ⑧** Band selection button (TUNER/BAND)
- ⑨** Media selection button (FUNCTION)
- ⑩** Open/close CD compartment (OPEN/CLOSE)
- ⑪** Volume control (VOLUME)
- ⑫** Play/pause button
- ⑬** Stop button
- ⑭** Forward button
- ⑮** Reverse button
- ⑯** Standby light
- ⑰** ON/OFF switch (POWER)
- ⑱** Increase volume
- ⑲** ON/OFF button
- ⑳** Sound selection button (EQ)
- ㉑** Band selection button (BAND)
- ㉒** Function button (FUNCTION)
- ㉓** Repeat button (REPEAT)

- ㉔** Play/pause button
- ㉕** Forward button
- ㉖** Stop button
- ㉗** Program selection button + (ALBUM PRESET +)
- ㉘** Stereo/Mono changeover (ST./MONO)
- ㉙** Find button (FIND)
- ㉚** Program selection button - (ALBUM PRESET -)
- ㉛** Reverse button
- ㉜** Programming button (PROG/MEM)
- ㉝** Random generator (RAND)
- ㉞** Timer button (TIMER)
- ㉟** Sleep function (SLEEP)
- ㊱** Reducing the volume
- ㊲** Switching the loudspeakers to mute (MUTE)
- ㊳** Connection memory card
- ㊴** Connection medium wave antenna
- ㊵** USB connection
- ㊶** Control cable to the subwoofer
- ㊷** Loudspeakers
- ㊸** Loudspeaker legs
- ㊹** Volume control (VOLUME) subwoofer
- ㊺** Headphone connection
- ㊻** Connection control cable
- ㊼** Power switch
- ㊽** Power cord
- ㊾** Left-hand loudspeaker connection (Speaker OUT L)
- ㊿** Left-hand connection audio appliance (AUX IN L)
- ①** Right-hand connection audio appliance (AUX IN R)
- ②** Right-hand loudspeaker connection (Speaker OUT R)

8. Inserting batteries into the remote control

For the remote control you need two batteries type micro AAA / 1.5 V

- ⇒ Open the battery compartment at the back of the remote control.
- ⇒ Insert two batteries into the battery compartment making sure to observe the polarity indicated in the battery compartment.
- ⇒ Carefully close the battery compartment lid until it clicks into place.

9. Handling batteries

Leaky batteries can damage the remote control.

- ⇒ If you intend not to use the remote control for a longer period of time, please remove the batteries.
- ⇒ Always replace both batteries and use batteries of the same type.
- ⇒ In case the batteries are leaky, wear protective gloves and clean the battery compartment with a dry cloth.

KH 2267 / 2268

10. Connecting

Loudspeakers

Both loudspeaker leads have a cinch plug at each end.

- ⇒ Connect the cinch plug of the right-hand loudspeaker to the right-hand loudspeaker connection 52.
- ⇒ Connect the cinch plug of the left-hand loudspeaker to the left-hand loudspeaker connection 49.

Additional audio appliance

You can connect other audio appliances such as e. g. a mini-disc player or a TV to the micro-system.

- ⇒ Connect the cinch plug (right-hand channel) of the audio appliance to the right-hand connection for the audio appliance 51.
- ⇒ Connect the cinch plug (left-hand channel) of the audio appliance to the left-hand connection for the audio appliance 50.

Subwoofer

- ⇒ Connect the control cable 41 of the micro-system to the connection of the control cable 46 on the subwoofer.

Connect and align the medium wave antenna

For the medium wave (MW) radio reception you must connect an additional antenna to the micro-system.

- ⇒ Take the supplied antenna out of the packaging.
- ⇒ Unwind the connecting cable from the antenna.
- ⇒ Erect the ring until you hear it click into place in the antenna base.
- ⇒ Push the antenna plug into the connection of the medium wave antenna 39.

There is a AM antenna for the radio reception of the USW transmitter on the micro-system.

- ⇒ Carefully roll out the dipole antenna fully, so that the micro-system has a good reception.
- ⇒ If the reception is insufficient, change the position of the dipole antenna.

Micro-system

- ⇒ Connect the power plug of the power cord 48 to a 230 V ~ /50 Hz wall socket.

11. Fold out the display for horizontal operation.

You can fold out the display to be able to read it more easily.

- ⇒ If you wish to fold out the display, please press at the top of the display 3.
- The display will fold out.
- ⇒ If you wish to fold the display in again, please press the display 3 down.
- The display will engage into the housing again.

12. Switching on and off

Switching on

- ⇒ Switch the power switch 47 on the back of the subwoofer into ON (I) position.

The micro-system is in standby mode and the standby light 16 lights up red.

Switching off

- ⇒ Switch the power switch 47 on the back of the subwoofer to OFF (0) position.

Play mode

- ⇒ In standby mode, please press the ON/OFF switch 17 on the micro-system.

13. Selecting the appliance/sound source.

You can choose between the following sound sources:

- CD
- AUX
- CARD-USB
- Tuner (radio)

- ⇒ Press the FUNCTION button 9 or 22, until the desired sound source appears on the display.

14. Adjusting the volume

You can adjust the volume via the remote control and the micro-system.

Remote control

- ⇒ To increase the volume press the button INCREASE VOLUME 18.
 - ⇒ Press the button until the desired volume is reached.
 - ⇒ To reduce the volume press the button REDUCE VOLUME 36.
 - ⇒ Press the button until the desired volume is reached.
- The set volume will appear 3 on the display

Micro-system

- ⇒ To increase the volume turn the volume control 11 clockwise.
- ⇒ To reduce the volume, turn the volume control 11 anti-clockwise.

The set volume will appear 3 on the display

Subwoofer

- ⇒ To increase the volume, turn the volume control 44 towards MAX.
- ⇒ To reduce the volume, turn the volume control 44 towards MIN.

Switching the loudspeakers to mute (Mute)

- ⇒ To switch the micro-system to mute, press the button SWITCH LOUDSPEAKER TO MUTE 37.

The volume flashes on the display.

- ⇒ To continue listening press the button SWITCH LOUD-SPEAKER TO MUTE 37 once again.

15. Adjusting the sound

You can adapt the sound quality to the respective type of music by means of the sound setting. You can choose between the following settings:

- Pop
- Jazz
- Pass
- Classic
- Rock

⇒ Press the SOUND SELECTION button 20 or 4, until the desired sound appears on the display 3.

If you adjust the sound setting while playing, the sound will change immediately.

16. Using headphones

You can connect stereo headphones to the micro-system with a 3.5 mm jack plug. The headphone socket 45 is situated on the front of the micro-system. When you have connected the headphones, the loudspeakers are disconnected and you will hear the sound via the headphones only.

⇒ Push the jack plug on the headphones into the headphone socket 45.

17. Setting the clock

You can only adjust the clock in standby mode.

⇒ Press the PROGRAMMING BUTTON 6 or 32 and keep it pressed for approx. three seconds.

⇒ In order to adjust the 24-hour or 12-hour mode, please press the button ►► 14 resp. 25 or ◀◀ 15 resp. 31.

⇒ To store the setting press the PROGRAMMING BUTTON 6 or 32

The hours indication flashes on the display.

⇒ To set the hours press the buttons ►► 14 resp. 25 or ◀◀ 15 resp. 31.

⇒ To store the setting press the PROGRAMMING BUTTON 6 or 32.

The minute indication will flash on the display.

⇒ To set the minutes press the buttons ►► 14 resp. 25 or ◀◀ 15 resp. 31.

⇒ Press the PROGRAMMING BUTTON again 6 or 32.

The time is set and active.

18. Setting the alarm function (timer)

You can program your micro-system to wake you up. For this purpose you can set the desired waking time, the sound source and the volume. The micro-system will then switch on and off according to the set time. You can be woken up by the radio or to the sound of a CD.

⇒ If you wish to be woken by a CD, please insert the desired CD into the CD compartment 1.

⇒ If you wish to be woken by the radio, please select a radio station by means of the BAND SELECTION BUTTON 8 resp. 21.

Setting the switch-on time

⇒ Press the TIMER button 7 resp. 34

The hour indication for the switch-on time flashes on the display.

⇒ To set the hours for the switch-on time press the button ►► 14 resp. 25 or ◀◀ 15 resp. 31.

⇒ To store the setting press the TIMER 7 resp. 34 button again.

The minute indication for the switch-on time flashes on the display

⇒ To set the minutes press the button ►► 14 resp. 25 or ◀◀ 15 resp. 31.

Setting the switch-off time

⇒ To enter the hours for the switch-off time press the TIMER 7 resp. 34 button.

The hours indication flashes on the display.

⇒ To adjust the hours press the button ►► 14 resp. 25 or ◀◀ 15 resp. 31.

⇒ To store the setting press the TIMER 7 resp. 34 button again.

The minute display for the switch-off time flashes on the display.

⇒ To set the minutes press the buttons ►► 14 resp. 25 or ◀◀ 15 resp. 31.

Setting the sound source

⇒ Press the TIMER 7 resp. 34 button.

The sound source indication flashes on the display.

⇒ Select the desired sound source by pressing buttons ►► 14 resp. 25 or ◀◀ 15 resp. 31.

Adjusting the volume

⇒ Press the TIMER 7 resp. 34 button.

The volume indication flashes on the display.

⇒ Select the desired volume using buttons ►► 14 resp. 25 or ◀◀ 15 resp. 31.

Storing the settings

⇒ Press the TIMER 7 resp. 34 button.

The alarm function settings will be shown on the display one after another. A clock symbol indicates that the alarm function is active.

KH 2267 / 2268

- ⇒ If you wish to activate/deactivate the alarm function, briefly press the TIMER **7** resp. **34** button.

After each switching on the alarm settings are shown on the display.

19. Activating the sleep function (Sleep)

You can determine a time after which the micro-system will switch off. You can select a switch-off time between 10 and 90 minutes.

- ⇒ Switch on the micro-system.
- ⇒ Press the SLEEP FUNCTION button **35**, until you have set the switch-off time.

The switch-off time is indicated on the display. Each time the button is pressed the switch-off time is reduced by ten minutes.

20. Radio operation / Selecting a band (USW/MW)

You can receive USW and MW stations with the micro-system.

- ⇒ To select the radio station press the BAND SELECTION BUTTON **8** resp. **21**.
- ⇒ In order to change over between the radio stations, press the BAND SELECTION BUTTON **8** resp. **21** again.
- ⇒ If the USW reception is impaired, switch over to MONO by means of the STEREO/MONO CHANGEOVER **23** function.

21. Operating the radio

Automatic search function

- ⇒ Switch on the tuner of the micro-system.
- ⇒ Press button **▶▶ 14** resp. **25** or **◀◀ 15** resp. **31** again and keep it pressed for a moment.

The search function begins and stops automatically when a frequency with sufficient reception has been found.

- ⇒ To re-start the search function press the button **▶▶ 14** resp. **25** or **◀◀ 15** resp. **31** again and keep it pressed for a moment.
- ⇒ To stop the search function press the button **▶▶ 14** resp. **25** or **◀◀ 15** resp. **31** again.

Manual search

With the manual search function you can carry out a fine adjustment function of the stations e. g. if reception is difficult.

- ⇒ Switch on the tuner of the micro-system.
- ⇒ To increase the reception frequency briefly press the button **▶▶ 14** resp. **25**.
- ⇒ To reduce the reception frequency briefly press the button **◀◀ 15** resp. **31**.

Storing the stations (memory)

You can store stations in up to 40 program locations (30 x USW and 10 x MW).

- ⇒ Set the desired station.

- ⇒ To store the station, press the PROGRAMMING BUTTON **6** or **32**.

The display for the program location flashes.

- ⇒ Select the desired program location with PROGRAM SELECTION BUTTON + **27** or PROGRAM SELECTION BUTTON - **30**.
- ⇒ To confirm the program location, press the PROGRAMMING BUTTON **6** or **32**.

The station is now stored in the selected program location.

Selecting stored stations

You can select the stored stations during radio operation.

- ⇒ Press PROGRAM SELECTION BUTTON + **27** or PROGRAM SELECTION BUTTON - **30**.
- ⇒ Press until the program location appears on the display.

22. CD functions

Inserting a CD

- ⇒ To open the CD compartment, press the button OPEN/CLOSE CD-COMPARTMENT **10**.

The flap of the CD compartment folds upwards.

- ⇒ Insert the CD into the CD compartment with the printed side facing up.
- ⇒ Press the CD down slightly until it is firmly positioned.
- ⇒ To close the CD compartment, press the button OPEN/CLOSE CD-COMPARTMENT **10** again.
- ⇒ Select the button FUNCTION SELECTION **9** resp. **22** the CD function.

The data (number of titles and total playing time) are shown on the CD display.

Removing the CD

- ⇒ To open the CD compartment, press the button OPEN/CLOSE CD-COMPARTMENT **10** on the micro-system.
- ⇒ Remove the CD.

Starting the play function

- ⇒ Press button **▶ || 12** resp. **24**.

Stopping the play function

- ⇒ Press button **■ 13** resp. **26**.

Interrupting/continuing the play function

- ⇒ While playing, press button **▶ || 12** resp. **24**.
- ⇒ To continue the play function press button **▶ || 12** resp. **24** again.

Next/previous title

- ⇒ To move on to the next title on the CD, press button **▶▶ 14** resp. **25**.
- ⇒ To play the previous title of a CD, briefly press button **◀◀ 15** resp. **31** twice.

Title forward/reverse

- ⇒ Press button ►► 14 resp. 25 or ◀◀ 15 resp. 31 while playing.
- ⇒ Keep this button pressed until the desired point in the title has been reached.

Repeat function (REPEAT)

By means of the repeat function you can repeat individual titles or all the titles of a CD (only after stopping the play function).

- ⇒ To repeat individual titles, press the REPEAT BUTTON 5 resp. 23 while playing.

REPEAT is shown on the display

- ⇒ To repeat all titles of a CD, press the REPEAT BUTTON 5 resp. 23 while playing.

REPEAT ALL will appear on the display.

- ⇒ To stop the repeat function of individual titles, press the REPEAT BUTTON 5 resp. 23 again.

REPEAT will disappear from the display.

Playing titles in random order (RANDOM)

- ⇒ Press the button RANDOM GENERATOR 33 on the remote control.

The titles on the CD will be played in random order.

Programming the order of titles

You can program an order in which the titles of a CD are to be played. This is only possible when the play function has been stopped

- ⇒ Press the PROGRAMMING BUTTON 6 or 32.

On the display program location1 of the title is shown that is to be played first. 64 program locations are available for this purpose.

- ⇒ Using button ►► 14 resp. 25 or ◀◀ 15 resp. 31 select the desired title for the program location.

- ⇒ To store the setting please press the PROGRAMMING BUTTON 6 or 32.

- ⇒ To program further titles repeat the described steps.

This programming will remain stored until you remove the CD from the CD compartment, switch to other function or switch off the micro-system.

Starting the programmed titles order

- ⇒ Press the PROGRAMMING BUTTON 6 or 32.

Memory and the first programmed titles appear on the display.

- ⇒ Start the play function by pressing button ► 12 resp. 24.

23. MP3 functions**Playing MP3 titles**

- ⇒ Place a CD with MP3s into the CD compartment 1.
- ⇒ Using the FUNCTION SELECTION button 9 resp. 22 select CD.

The number of contained albums, number of titles and MP3 appears on the display.

- ⇒ To start the play function of the CD press button ► 12 resp. 24.
- ⇒ To fade in additional MP3 information (ID3 tag) press the FIND BUTTON and keep it pressed 29 for two seconds.

If the CD contains several albums, please proceed as follows:

- ⇒ To select an album, press PROGRAM SELECTION BUTTON + 27 or PROGRAM SELECTION BUTTON - 30.
- ⇒ Start the play function of the entire album by means of button ► 12 resp. 24.
- ⇒ Or select a title by pressing button ►► 14 resp. 25 or ◀◀ 15 resp. 31.
- ⇒ Start the play function by means of button ► 12 resp. 24.

Stopping the play function

- ⇒ Press button ■ 13 resp. 26.

Next/previous title

- ⇒ To play the next MP3 title on the CD, press button ►► 14 resp. 25.
- ⇒ To play the previous MP3 titles on the CD, press button ◀◀ 15 resp. 31 twice in succession.

Title forward/reverse

You can play certain points within an MP3 title

- ⇒ Press button ►► 14 resp. 25 or ◀◀ 15 resp. 31 while playing.
- ⇒ Keep this button pressed until the desired point in the title has been reached.

Search functions

In search mode you can search for titles or albums on your MP3 CD according to file names. You can have the search done by the first letter (A-Z) or by numbers (0-9). If there is no file name beginning with "A", the display will show "A-NONE".

- ⇒ Insert a CD with MP3s into the CD compartment.
- ⇒ Using the FUNCTION SELECTION button 9 resp. 22 select CD.
- ⇒ To start searching mode, press the FIND BUTTON on the remote control once 29.

A magnifying glass symbol appears on the display and the first name with the letter "A" will be displayed. If there is no file name beginning with "A", the display will show "A-NONE".

- ⇒ Press button ►► 14 resp. 25 or ◀◀ 15 resp. 31 until the desired first letter or number appears on the display.
- ⇒ To play the title press button ► 12 resp. 24.

KH 2267 / 2268

⇒ If several file names begin with "A", press button **▶▶ 14** resp. **⏸ 25** for two seconds.

The magnifying glass symbol in the remote control stops flashing. The letter A starts flashing.

⇒ Press button **▶▶ 14** resp. **⏸ 25** again.

The other file names beginning with A will be shown on the display.

⇒ To start the album search function, press the FIND BUTTON **29** twice.

A magnifying glass symbol and Album appear on the display. All album names beginning with A will be shown.

⇒ Press button **▶▶ 14** resp. **⏸ 25** or **◀◀ 15** resp. **31** until the desired album or number appears on the display.

⇒ To play the album press button **▶ 12** resp. **24**.

⇒ To display the existing titles of the desired album, press button **▶▶ 14** resp. **⏸ 25** for two seconds.

The album display will go out and the first title will be shown.

⇒ Press button **▶▶ 14** resp. **⏸ 25** or **◀◀ 15** resp. **31** until the desired title is shown on the display.

⇒ To play the title press button **▶ 12** resp. **24**.

Displaying file information

You can have the file name, name of the artist and the album title belonging to the title shown on the display.

⇒ Start an MP3 title.

⇒ Press the FIND BUTTON **29** while playing and keep it pressed for two seconds.

The album, the titles and the artist are shown on the display.

⇒ To call up the overall title display again, press the FIND BUTTON **29** again for two seconds.

Programming the MP3 title order

You can program the order in which the titles on an MP3 CD are to be played. 64 program locations are available for this purpose. This is only possible when the play function has been stopped

⇒ Press the PROGRAMMING BUTTON **6** or **32**.

The number of albums and the program location 1 of the title that is to be played first is displayed.

⇒ Using button **▶▶ 14** resp. **⏸ 25** or **◀◀ 15** resp. **31** select the desired album for the program location.

⇒ To store the setting press the PROGRAMMING BUTTON **6** or **32** again.

The title display for program location 1 flashes on the display.

⇒ Using button **▶▶ 14** resp. **⏸ 25** or **◀◀ 15** resp. **31** select the desired title for the program location.

⇒ To store the setting press the PROGRAMMING BUTTON **6** or **32** again.

⇒ To program further titles repeat the described steps.

This programming will remain stored until you remove the MP3 CD from the CD compartment, switch to other function or switch off the micro-system.

Starting the programmed titles order

⇒ Press the PROGRAMMING BUTTON **6** or **32**.

Memory and the first programmed titles appear on the display.

⇒ Start the play function by pressing button **▶ 12** resp. **24**.

Checking the programmed titles order

⇒ Start the play function by pressing button **▶ 12** resp. **24**.

⇒ Press the PROGRAMMING BUTTON **6** or **32**.

Upon each press a stored title in ascending order of the program locations will appear on the display.

MP3 repeat function (Repeat)

By means of the repeat function you can repeatedly play individual titles from an MP3 CD or all titles of an MP3 CD.

⇒ To repeat a title press the REPEAT BUTTON **5** resp. **23** while that title is playing.

REPEAT is shown on the display

⇒ To repeat all titles of an MP3 CD press the REPEAT BUTTON **5** resp. **23** twice during playing.

REPEAT ALL will appear on the display.

⇒ To repeat all titles of an MP3 CD, press the REPEAT BUTTON **5** resp. **23** three times in succession during playing.

REPEAT ALBUM is shown on the display.

⇒ To terminate the repeat function press the REPEAT BUTTON **5** resp. **23** four times during playing.

24. USB and memory card functions

Due to the numerous amount of available storage media, no guarantee can be given for the compatibility with all current and future storage media.

Playing MP3 from USB stick or memory card

You can play MP3 titles from USB sticks, MS, SD or MMC memory cards.

- ⇒ Insert the USB stick into the USB connection ④① of the micro-system,
- ⇒ or insert an MS-, SD- or MMC memory card into the memory card connection ③⑧.
- ⇒ Using the FUNCTION SELECTION button ⑨ resp. ②② select the function CARD-USB.
- ⇒ Press button ■ ⑬ resp. ②⑥.

The number of contained albums, number of titles and MP3 appears on the display.

- ⇒ To start the play function press button ► || ⑫ resp. ②④.

Searching for an album

- ⇒ Press the FIND BUTTON ②⑨.

A magnifying glass symbol appears on the display ③ and the numbers and names of the albums are displayed.

- ⇒ Using button ►► ⑭ resp. ②⑤ or ◀◀ ⑮ resp. ③① select the desired album.

- ⇒ To start the play function press button ► || ⑫ resp. ②④.

- ⇒ To call up the overall title display press the FIND BUTTON ②⑨ for two seconds

The album, the titles and the artist are shown on the display.

- ⇒ Operate as described in the chapter "MP3 functions".

25. Cleaning and care

⚠ Danger of life-threatening electric shock:

- Never open the appliance housing. No operating elements are located inside the device.
- Never immerse the appliance components into water or other liquids!
- Do not allow any liquids to penetrate the housing.

Cleaning the casing:

- ① Clean the housing surface with a slightly damp cloth

- ⇒ First pull the plug out of the socket.

26. Disposal



Micro-system, subwoofer and loudspeakers

- Have the micro-system or parts of it disposed of by a professional disposal company or by your communal disposal facility.
- Never dispose of the micro-system with the normal household refuse.
- Observe the currently valid regulations. In case of doubt, please contact your waste disposal centre.

Batteries

- Never dispose of the micro-system with the normal household refuse.
- Batteries can contain toxic substances, which may damage the environment. Therefore dispose of the batteries in accordance with legal regulations. Never dispose of batteries in the normal household refuse

27. Importer

Kompernaß GmbH
Burgstraße 21
D-44867 Bochum
www.kompernass.com

KH 2267 / 2268



Warranty

Micro-system KH2267 / 2268

In order to ensure free repair, please contact the service hotline. Keep your cash receipt ready for this purpose.

Kompernaß Service United Kingdom
Tel.: 08707/876177

www.mysilvercrest.de

Fill in this section and submit it with the appliance!

Please write the sender's address clearly:

Last name

First name

Street

Pincode/Place

Country

Telephone

Date/Signature

Error description:

Multiple horizontal lines for writing the error description.

